



### DESCRIPTION

'AE' Built in Transducer type Power Meter is equipped with a measuring transducer & a moving coil movement. It measures Active, Reactive & Apparent power in Single Phase & Three Phase system.

### FEATURES

- ◆ The meter doesn't require external transducer, hence panel wiring is reduced.
- ◆ Auxiliary supply is not required (Self - Powered).

### ELECTRICAL SPECIFICATIONS

- ◆ TYPE : Active, Reactive & Apparent Power.  
1 Ph / 3 Ph – 2 EL – 3 W / 3 Ph – 3 EL – 4 W
- ◆ INPUT VOLTAGE : 110V / 240V / 415V / 440V.
- ◆ INPUT CURRENT : 1A / 5A
- ◆ INPUT FREQUENCY : 50Hz or 60Hz
- ◆ MEASURING UNIT : Active Power : W, kW, MW  
Reactive Power : Var, kVar, MVar  
Apparent Power : VA, kVA, MVA
- ◆ ACCURACY :  $\pm 1.5\%$  of full scale range
- ◆ VA BURDEN : Voltage : 3VA  
Current : 1VA
- ◆ INSULATION RESISTANCE: Greater than 20M  $\Omega$  at 500V DC
- ◆ DIELECTRIC TEST : 2kV RMS for 1 minute.
- ◆ OPERATING TEMP. : 0°C to 55°C
- ◆ STORAGE TEMP. : -20°C to 70°C
- ◆ HUMIDITY : Up to 95% RH
- ◆ CONFORMS TO : I.S. 1248 / I.E.C. 60051 (Part 3)

### MECHANICAL SPECIFICATIONS

MODEL	SIZE (mm)	PANEL CUTOUT (mm)	WEIGHT (Approx. gms.)
BIAPM 96	96 x 96 x 157	92 x 92 <sup>+0.8</sup>	800
BIAPM 144	144 x 144 x 157	138 x 138 <sup>+1.0</sup>	1200

**BIAPM 110**, Size 110 x 110mm (available in 3P 2E 3W & 3P 3E 4W model)

### DIMENSIONS

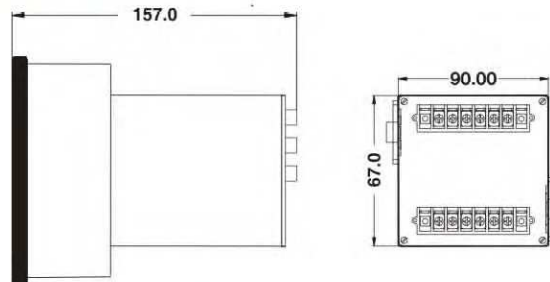

### TERMINAL CONNECTIONS

For 96 x 96				For 144 x 144			
Type	Voltage	Current	Aux. Supply	Type	Voltage	Current	Aux. Supply
1Ph	L1, N	1S, 1L	Self Powered	3Ph – 2EL – 3W	L1 = 3 L2 = 7 L3 = 11	1S = 2, 1L = 1 3S = 10, 3L = 9	Self Powered
3Ph – 2EL – 3W	L1, L2, L3	1S, 1L 3S, 3L		3Ph – 3EL – 4W	L1 = 3 L2 = 7 L3 = 11 N = 8	1S = 2, 1L = 1 2S = 6, 2L = 5 3S = 10, 3L = 9	
3Ph – 3EL – 4W	L1, L2, L3, N	1S, 1L 2S, 2L 3S, 3L					



### TYPICAL WIRING DIAGRAM

For 96 x 96

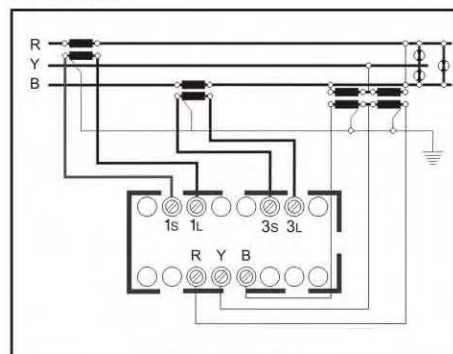

For 144 x 144

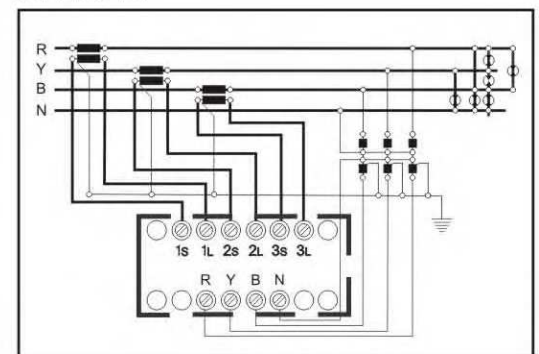

### Ordering information

- 1) Type 2) Size 3) Model 4) Active, Reactive or Apparent Power  
 5) Current with CTR if applicable 6) Voltage with PTR if applicable 7) Full scale indication.